

Instruction manual

for electromagnetic piston pumps type ET, EK, EM

1. Description

1.1. General

ET_ - EK_ - EM_'s type are compact solenoid driven oscillating piston pumps.

The pump and the driving mechanism are integrated without any shaft seal in a totally waterproof system.

The pump is self priming to a height's difference from 1 to 3 meters according to the type of pump, which limits itself automatically its maximum pressure.

1.2. Function mode

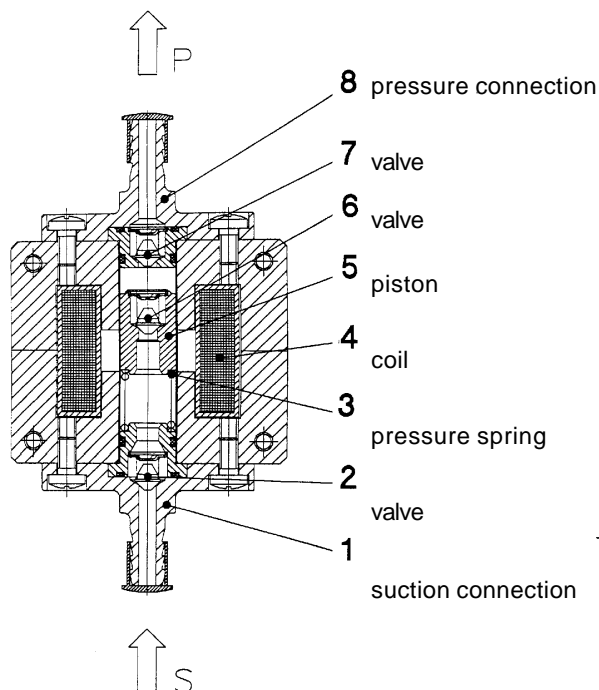

The piston (5) is moved by the electromagnetic field generated by the single wave diode rectified current flowing through the coil (4).

Each current pulse moves the piston against the pressure spring (3). This movement, by reducing the volume in the suction chamber, opens the valve (6) set in the piston to let the liquid run to the pressure side.

When the current pulse dies the pressure spring pushes back the piston toward the pressure side. The increase of pressure closes the piston valve (6) and the liquid flows through the valve (7) set in the pressure connection (8) and into the pressure pipe.

Eckerle Industrie Elektronik GmbH

Benzstrasse 12a, D-76316 Malsch, Germany

Tel.: + 49 (7246) 9204-0 Fax.: +49 (7246) 9204-44

This movement creates a low pressure in suction chamber which opens the valve (2) set in the suction connection (1). The liquid is sucked into the pump and the cycle starts again , 60 times per second (60 or 50 Hz, depending the mains' frequency).

The piston size and the length of its displacement define the flow rate.

The pressure limits itself automatically, and if the liquid flow is stopped, the pump will continue to run without damage .

The pumps works not only tied to the standard tension and frequency but can be piloted by a frequency regulation or a pulse control unit.

The ground elements, piston and bushing, guarantee a minimum wear and a high life's duration.

By the use of different materials the pump can be employed with a wide range of mediums at different temperatures.

1.3. Markings

1.3.1. Individual label of pumps type ET - EK

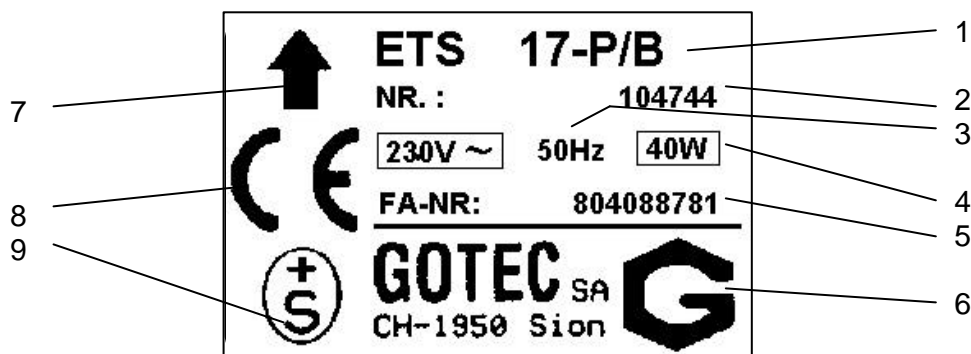



- | | |
|---------------------|---|
| ✎ ETS 17-P/B | : Manufacturer type classification |
| ETS | : Model of end fittings - (<i>plastic barbed tube</i>) |
| 17 | : Type of pump - (<i>tied to the pressure : 1,7 bars</i>) |
| P | : Materiel of sealing - (<i>Perbunan²</i>) (NBR) |
| B | : Other descriptions - (<i>piston's bushing in bronze</i>) |
| ✎ NR. : 104744 | : Manufacturer fabrication classification |
| ✎ V 230 50Hz | : Voltage and frequency supply |
| ✎ 40W | : Power of the pump (Watt) |

Eckerle Industrie Elektronik GmbH
 Benzstrasse 12a, D-76316 Malsch, Germany
 Tel.: + 49 (7246) 9204-0 Fax.: +49 (7246) 9204-44

- ✍ FA-NR: 804088781 : **Individual pump number** (follow up)
- 8 : Year of fabrication - (**1998**)
- 04 : Month of fabrication - (**04 = April**)
- 088781 : Individual number - (**88781th** pump tested on the automatic control bank)

- ✍  **GOTEC SA** : Logo +manufacturer name and address
- CH- 1950 Sion

- ✍  : Flow direction
- ✍  : Label of conformity (CE= European norms)
- ✍  : Swiss distinguishing security sign

1.3.2. Individual pump's label type EM

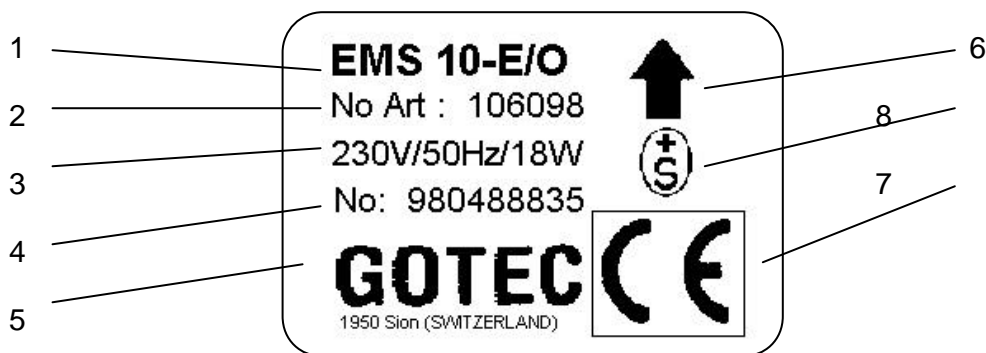

- 1: **EMS 10-E/O** : Manufacturer type classification
- EMS : Model of end fittings - (*for soft tubing*)
- 10 : Type of pump - (*tied to the pressure : 1,7 bars*)
- E : Seals & valves material - (**EPDM**)
- O : Other descriptions - (*without piston's coating*)
- 2: NR. : 106098 : Manufacturer fabrication classification
- 3: 230 V / 50Hz / 18W : Voltage and frequency supply / Power consumption.
- 4: FA-NR: 980488835 : **Individual pump number** (follow up)
- 98 : Year of manufacture - (**1998**)
- 04 : Month of manufacture - (**04 = April**)
- 88835 : Individual number - (**88835th** pump tested on the automatic control bank)
- 5: **GOTEC** : Logo + name +address of manufacturer
- 1950 Sion (SWITZERLAND)
- 6:  : Flow direction
- 7:  : Label of conformity (CE= European norms)
- 8:  : Swiss distinguishing security sign

Eckerle Industrie Elektronik GmbH
 Benzstrasse 12a, D-76316 Malsch, Germany
 Tel.: + 49 (7246) 9204-0 Fax.: +49 (7246) 9204-44

1.3.3. Molded label

The following two types of inscriptions are molded on the coil body G15, G17 and G21:

- G15 or G17 or G21 : type of coil
- 24V~or 100V~or 110V~ou 230V~ : voltage and alternative current mark.
- 60 or without mark : frequency (60 or 50 Hz)

The following two types of inscriptions are molded on the coil body G08 :

- 230V/50-60Hz : Voltage and frequency (as well as 110V/60Hz, 24V/50-60Hz and 12V/50-60Hz)
- 100% ED : Using factor

1.4 Performances

See the general prospectus or the technical data sheets.

2. Use

2.1. Mounting

To avoid any kind of twisting, forcing and exaggerated pulling on the electrical wiring, it is recommended to fit the hydraulic tubing first.

To avoid a possible clamping of the piston by solid particles present in the fluid, the mounting of a filter before the pump is needed.

2.1.1. Hydraulic

It might be easier to connect the tubing before fastening the pump in its place.

The **ETS** and **ETX** models with barbed end fitting request to force a soft plastic pipe (PVC, ...) with an inner diameter of ~8 (mm) around the barbed plastic (**ETS**) or stainless steel (**ETX**) end fitting set in the pump. The plastic pipe should be slid until its covers completely the teeth or the swelling of the fitting. This mounting will be assured by the use of a metallic clamp which avoid the loosing of the pipe.

Eckerle Industrie Elektronik GmbH

Benzstrasse 12a, D-76316 Malsch, Germany

Tel.: + 49 (7246) 9204-0 Fax.: +49 (7246) 9204-44

The connection parts with inner- or outer-threads request a complete screwing of the adapter on the end fitting. M10X1 (ETK & ETU) or G¹/₈ (ET & ETG). The waterproof between the pipe's adapter and the end fitting of the pump should be made by an O-ring or by a Teflon tape.

The plastic tube should not be bent too much sharply to avoid pinching, mostly, on the suction side of the pump.

The tube's quality is chosen in function of the using pressure's pump.

2.1.2. Fastening

Type ET: The four holes inside the corner rivets holding the metal stacking allow the mounting of M3 screws to fasten the pumps into any board. It is recommended to add a damper (rubber feet) between the pump and the board to absorb the 50 or 60 Hz line frequency.

Type EK: The nozzles allow a mounting with stirrups. It is recommended to add a damper (rubber feet) between the fittings of the pump and the board to absorb the 50 or 60Hz line frequency.

Type EM: Due to its light weight, the EM type could be simply hang from its tubing. The nozzles allow a mounting with stirrups too, in this case, it is recommended to add a damper (rubber feet) between the end fittings of the pump and the board to absorb the 50 or 60 Hz line frequency.

It is important to leave a free space around the pump to let it move freely so it will not rub or knock.

2.1.3. Electrical

The electrical wiring is done in accordance to the following diagram :

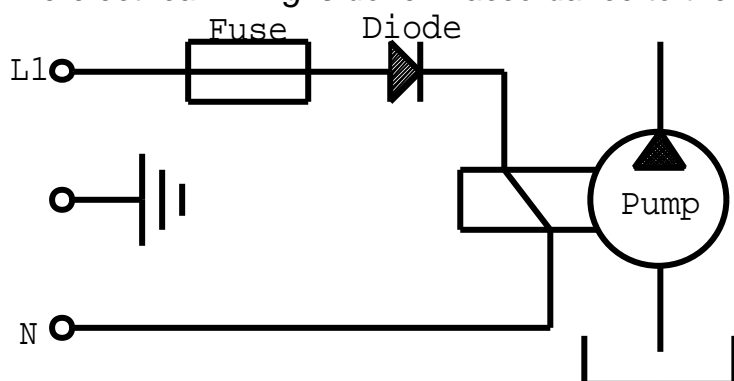

The electrical connection to the pump is made with **receptacles flat** female plug connectors (DIN 46247) **6.3 mm** wide. It is recommended to use plastic housing or thermoretractile sheath for the connectors to avoid any accidental contact with the metal.

Eckerle Industrie Elektronik GmbH

Benzstrasse 12a, D-76316 Malsch, Germany

Tel.: + 49 (7246) 9204-0 Fax.: +49 (7246) 9204-44

230V and 110V need a **diode n° 1N 4007** or with *similar characteristic* :

- *Nominal current* : 1 A
- *Shock current* : 30A (8ms)
- U_{RN} : 1000 V
- *Pick tension* : 1200 V
- U_F at I_F : 1.2 V

Which is set on one of the incoming line.

If the tension is equal to **12V or 24V** the nominal current of the diode has to be more than **6A**.

A **fuse** of maximum **0.5 A** (for 230 V) is added along the circuit.

When the pump is switched off, a induced tension of several hundreds volts may be generated. So it is recommended to put a varistor (VDR) (oxide metallic varistance) to attenuate this tension. This condition is valid for all types of pumps.

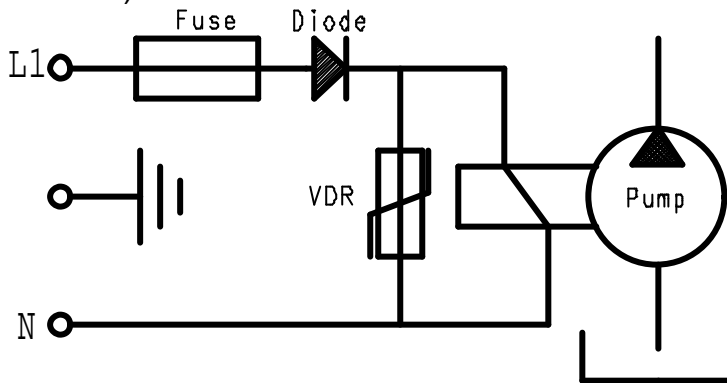

This electronic part must be mounted after the diode and the fuse, parallel to the pump (see electronic diagram). This mounting is necessary when the pump is stopped and started often by a commutator or a relay. The VDR will avoid the sticking of the commutator's contacts and protect the coil against a possible breakdown.

Characteristics of the varistor :

- U_{eff} : 275 VAC
- Response time* : $\sim < 25ns$
- Admissible permanent charge* : $\geq 1W$

The ET_ series pump may be connected to ground by riveting or fastening with a M3 screw, a connection cable terminal to one of the four holes, which are in the corners of the steel laminated body.

The EK_ series pump may be connected to ground by drilling a hole in the metallic frame of the pump and fastening a connector cable terminal.

Eckerle Industrie Elektronik GmbH
Benzstrasse 12a, D-76316 Malsch, Germany
Tel.: + 49 (7246) 9204-0 Fax.: +49 (7246) 9204-44

CAUTION : Not damage the coil during the drilling of the hole.

The EM_ series pump already has a ground connector. The connection diagram is draw on the label of each pump.

When the electrical connection is done, any contact with parts under electric tension must be avoid. The electrical connections have to be insulated with a plastic house or with a thermoretractible sleeve.

During the mounting of the pump, watch carefully that the pump's connections must not come in contact with any liquid coming from defective tubing or fitting.

Pumps mounted in permanent installations have to could be disconnect from the main by a switch effective on the three wire, with at least a contact opening of 3 mm wide.

2.2. Using the pump

It is strongly recommended to never let the pump run without liquid for more than a few minutes.

Applying the current makes the piston run immediately. A fairly high humming sound is heard until the liquid reaches the pump.

After a variable time the warming up of the coil will slightly decrease the flow rate performances of the pump. A part of the electrical energy is turned into heat rather than mechanical strength, The pressure is almost not influence by this.

When the pressure rises to its maximum the pump come close to a stop, the piston keep on moving very slightly but the flow rate is roughly null. The liquid flows back along the clearance let between the piston and the brass (stainless steel) jacket. The pump warms up but handles this condition without damage.

The pump can be started with any level of back pressure as long as this strength is at the most equal to the maximum pressure accepted by the pump.

2.3. Maintenance

<p>Eckerle Industrie Elektronik GmbH Benzstrasse 12a, D-76316 Malsch, Germany Tel.: + 49 (7246) 9204-0 Fax.: +49 (7246) 9204-44</p>
--

The ET_ - EK_ - EM_ pumps are free of maintenance. They are not suppose to be dismantled by the customer.

The warranty is tied to the strict observance of this rule.

3. Security

✍ **The respect of the mounting instructions (2.1.1. Hydraulic, 2.1.2. Fastening, 2.1.3. Electrical) brings a total security to the customer.**

✍ The following **dielectric tests** are applied to:

coils during the manufacture : **5000** volts for **2** seconds

assembled pumps type ET_ - EK_ : **3500** volts for **1** second

assembled pumps type EM_ : **2500** volts for **1** second

3.1. general precaution

✍ **The ET_ - EK_ - EM_ are devices made to pump liquids. Any other kind of uses are prohibited.**

✍ **The pumps generates warmth (45-60°C), which can hurt lightly. It is recommended to mount the pump in a way to avoid any accidental contacts.**

✍ The pump should not be hit. The plastic end fitting are breakable, the brass and stainless steel end fittings might be crushed if the pump is dropped.

✍ The coil body, black plastic part inserted in the metallic block, reaches an average temperature of 45 to 60 °C under normal use. This heat must be evacuated, so foresee space around the pump.

✍ The pump weights 450 to 600 grams and must be handle with attention to avoid injuries.

✍ The pump vibrate at 50 or 60 (Hz). Cares must be taken to keep clear of contact with other fastened parts.

✍ The two electrical connections (plus & minus) must be protected against a common metallic contact which will turn into a short circuit. It is recommended to use plastic housing for the connectors to avoid any accidental contact with electrical conducting materials.

3.2. Dry running

Eckerle Industrie Elektronik GmbH

Benzstrasse 12a, D-76316 Malsch, Germany

Tel.: + 49 (7246) 9204-0 Fax.: +49 (7246) 9204-44

A long dry running will conduct to :

- ✍ The melding of internal parts.
- ✍ The stop of the piston movement.
- ✍ The overheating of the coil.
- ✍ The fusion of the copper wiring, what will stops the run of the current.
- ✍ The blow up of the fuse by short circuit.
- ✍ The pump might stop by seizure at any time through this process.

Eckerle Industrie Elektronik GmbH
Benzstrasse 12a, D-76316 Malsch, Germany
Tel.: + 49 (7246) 9204-0 Fax.: +49 (7246) 9204-44